

It's not just a bag, it's a solution...

*We have thought of everything, so you don't have to.
We provide the best comprehensive package of any manufacturer.*



Speed Up Front End Bagging

You aren't saving money if you have to open up another check stand. We have a full line of patented dispensing options.

Bags are spool loaded right out of the box • Easy opening • Stays open while you load • Clean & uniform look at your registers.

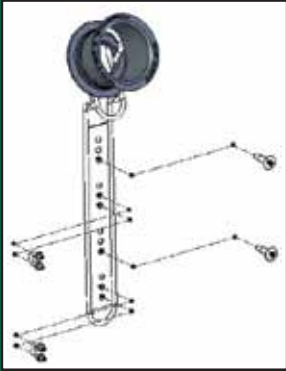

Pole mounts to any vertical surface.

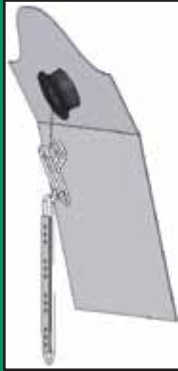

Spool holding bags clicks onto pole.

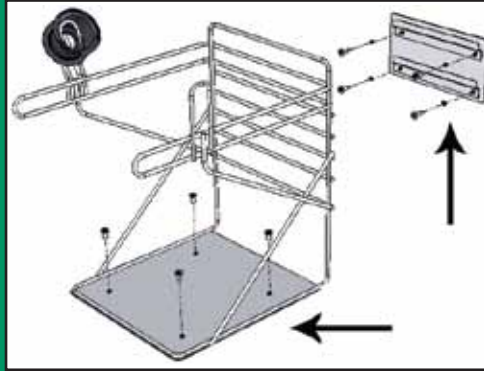

Wave top rack mounts to a shelf or can be hung at the end of your check stand with our adjustable plate bracket.



Spool holding bags mounts to one side of rack. Bag opens to prong on other side to hold open.

These bags are packaged on a spool and come with a bracket for easy dispensing.

Mounting the Bracket: Pick a flat, smooth, hard, vertical surface that is solid enough to hold screws and approximately 25 lbs. The bracket should have the oval part up. Insert the four screws into the surface you select. See diagram.

Mounting the bags: Clip the small side of the spool onto the bracket. You should hear a click and the spool and bags should stay in place. Pull bags off the spool one at a time.

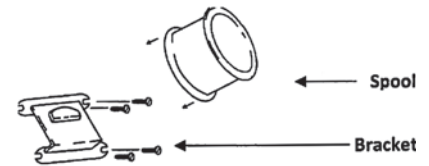

Thicker Handles & More Usable Space

**Compare specifications correctly.
Get what you pay for.**

- Our handles are thicker. Feel them! Strength where you need it.
- More value for you and your customer.
- Loading confidence. Get more in the bag.
- Measure wave tops from the shoulder of the bag, not from the top of the wave.
 - You can't put food in the handles. They are not part of the capacity of the bag.

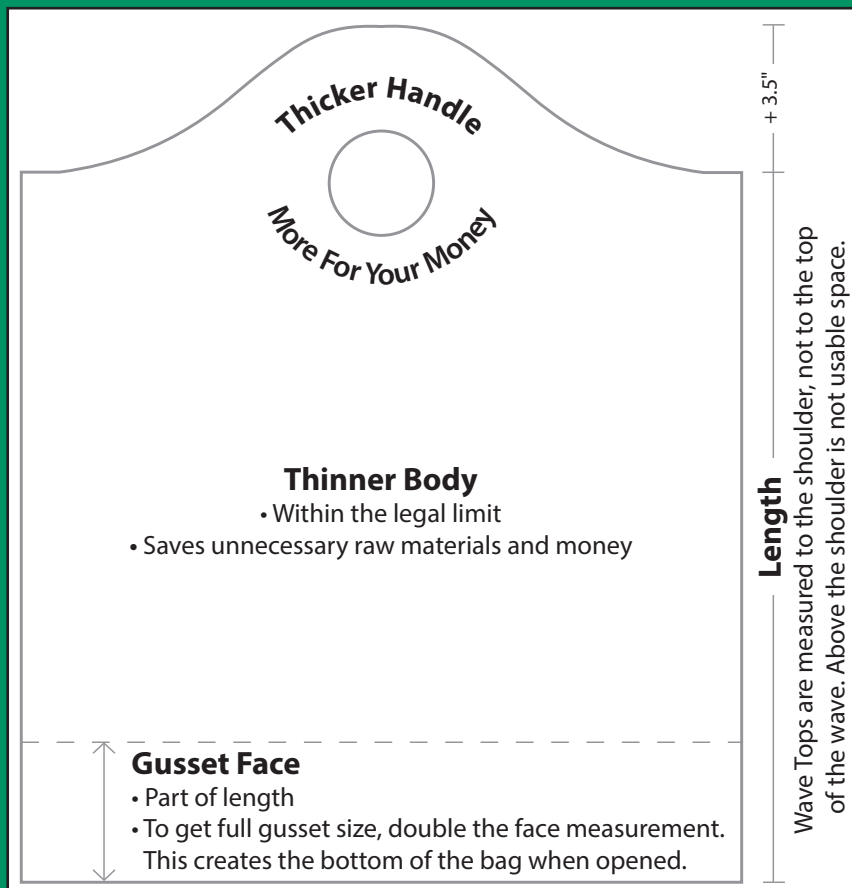

Let us print for you!

- 8 color press
- Both sides
- Photo quality printing
- No printing up-charge for extra colors
- A walking billboard. Market your store!
- design creation and art support.
- Stock designs: slug-in store name or brand
- Co-op advertising in Full color

Check the Facts... Sales people will say anything to get an order!

Is the bag LEGAL?

- We want to sell bags, but we won't lie to do it. We are in this together.
- A citation or bad press will cost you far more than you saved on a bag that is not compliant.
- Our bags have the EcoLogo ATP001 certification
 - EcoLogo test by an accredited lab is required in most ordinances
 - it is not good enough that the bag holds 22lbs or has a Walk Test certification

Get proof - "In God we trust. All others bring data." W.E. Deming

- if the bag is legal it should be posted on Los Angeles Counties site, www.aboutthebag.com. If it is not, it's probably not legal and has not passed the EcoLogo test.
- Ask for the certification with the accredited lab letterhead.

What is required and what's not?

• Print Requirements:

- Nearly all ordinances have required text. Make sure your bag is properly printed.
- We keep track of all these requirements and can advise you accordingly.

• You do NOT have to offer paper bags... at all!

- if someone is telling you differently, they are wrong.
- No ordinance requires that you sell or offer paper bags. it is simply an option.
- if you choose to offer paper, you must charge a minimum of 10 cents for each bag.

• You can give away reusable bags for FREE

- Yes, this is true in most ordinances.
- This is your chance to offer customers quality bags and service.
- We recommend promotional periods or free bags with a minimum purchase.
- This is not an option with paper bags.

• Do you have to give free bags to WIC/SNAP customers?

- This is different in each ordinance. We can show you the requirement for each.
- if you choose to or have to provide a free bag, why not make it a reusable bag?
 - use less because you can load more.
 - Strong handle for carrying.
 - Best possibility of reuse to lessen bag output.



Don Mitchell - DM Packaging, Inc.
281-859-4933 (Houston) - 1-800-890-7056 (toll-free)
832-693-3772 (mobile) - 281-550-7936 (fax)
don@dmpackaging.com - www.dmpackaging.com

*State of Texas Historically Underutilized Business (HUB)
City of Houston Woman Business Enterprise (WBE)*

What does your bag say about your store? Project your image!



What image does this project?

- We have a boring one color bag
- You have no idea what kind of store we are
- This looks like a single use t-shirt bag

**El Gran
Supermercado**

What image does this project?

- We sell fresh produce
- Shop here!

**Farm to Table
Neighborhood Market**

What image does this project?

- A classy look
- Market to your clientele